

SSI Technologies – Application Note PS-AN7

MediaGauge™ (Model MG-MD) Digital Pressure Gauge

Product Overview

Product Description

The MediaGauge™ MG-MD is a multi-functional digital pressure gauge consisting of a media isolated piezoresistive pressure sensing element, signal conditioning circuitry for temperature and calibration compensation, a 304L stainless steel pressure port and a LCD back lit display. The MG-MD digital pressure gauge has an **accuracy of $\pm 0.25\%$ full scale**.

The MediaGauge™ MG-MD digital pressure gauge is powered by an external 8 – 30 Vdc external power supply and comes standard with a wide variety of functions – multiple pressure unit display readings (PSI, BAR or MPA units); memory storage of maximum peak pressure reading; zero adjustment; a 4-20 mA current output along with a limit switch (NPN transistor) to interface to monitoring and control systems.

The MediaGauge™ MG-MD is made of all laser-welded 304L & 316L stainless steel for optimal media isolation and usage in a wide variety of media. These compact 3 inch, robust digital pressure gauges measure pressures from 15 PSI to 5000 PSI and are ideal for a variety of industrial and commercial applications such as process control, refrigeration, compressors, pumps, hydraulics, pneumatics and waste water.

The MediaGauge™ MG-MD digital pressure gauge has better accuracy, longer life and standard multiple functions which make it a better choice than mechanical pressure gauges.



MediaGauge™ Model MG-MD with 2 meter cable.

Product Features

- **Superb Accuracy:** $\pm 0.25\%$ Full Scale
- **Pressure Ranges:** 15, 50, 75, 100, 200, 300, 500, 750, 1000, 1500, 2000, 3000, 5000 PSI
- **Keypad Operated Functions:** Auto zero; peak hold and high and low pressure set points
- **Monitoring and control outputs:** 4-20 mA output and a limit switch (NPN transistor output) controlled by the high and low keypad programmable pressure set points.
- **Operating Temperature:** -10°C to 60°C
- **Storage Temperature:** -20°C to 85°C

SSI Technologies – Application Note PS-AN7

MediaGauge™ (Model MG-MD) Digital Pressure Gauge

Product Overview

- **Typical Applications:** General Purpose, Test, Process Control; MRO, Water, Compressors, Refrigeration; Fuel Cells; Pumps; Hydraulics; Spraying Systems; Pneumatics; Flow; Robotics; Agriculture; Hydrogen Storage
- **NEMA 4X Rating**
- **NIST traceable certificates available**
- **Chemical Compatibilities:** Any gas or liquid compatible with 304L Stainless Steel. For example, Motor Oil, Diesel, Hydraulic fluid, brake fluid, water, waste water, Hydrogen, Nitrogen, and Air.
- **Multiple Pressure Units:** PSI, BAR, MPA (kg/cm²)
- **Compact, Robust Package:** 3 inches with black ABS Thermoplastic case

Measurement Technology

In general, pressure measurement technology translates a force from an induced pressure into an electrical quantity. In digital pressure gauges, the electrical quantity is then translated into pressure units and digitally displayed.

The SSI's MediaGauge™ MG-MD digital pressure gauge consists of a 304L stainless steel input pressure port; a piezoresistive pressure sensing element; signal conditioning circuitry for temperature and calibration compensation; a LCD that displays the pressure measured in either PSI, BAR or MPA (kg/cm²) units; a 4-20 mA output signal and a limit switch (NPN transistor output).

The piezoresistive sensing element contains an oil-filled micro-machined 316L stainless steel convoluted diaphragm and a silicon crystal semiconductor. The silicon crystal sensor is mounted on a 304L stainless steel housing and laser welded to the diaphragm. Optimal media isolation is achieved when the media's pressure acts directly on the 316L stainless steel diaphragm and is then transferred through the oil to the silicon sensor.

Strain gauges (resistive elements) in the silicon are used in a Wheatstone Bridge circuit. When the media's pressure is applied, the resistivity of the strain gauges changes proportional to the pressure applied. One leg of the bridge measures the input pressures port. The other leg of the bridge is connected to the reference port (vacuum pressure 0 PSI) the input pressure port is compared to.

Since piezoresistive pressure sensors are sensitive to changes in temperature, the MediaGauge™ MD-MG digital pressure gauge uses signal conditioning to compensate for temperature and calibration prior to outputting the LCD signal. The output signal is then converted into one of 3 user selectable forms (select units with the ON/UNIT/OFF button):

- 1) PSI
- 2) BAR
- 3) MPA (kg/cm²)

The MediaGauge™ MG-MD digital pressure gauge will display the pressure reading after the ON/UNIT/OFF button is depressed. The pressure measurement reading is updated 3 times per second.



SSI Technologies – Application Note PS-AN7

MediaGauge™ (Model MG-MD) Digital Pressure Gauge

Product Overview

The MediaGauge™ MG-MD also has two keypad programmable pressure set points – a low limit set point and high limit set point. These set points control the limit switch (NPN transistor output).

To understand this functioning lets look at a typical application for the pressure set point function to control relays in process and industrial applications.

Let's assume a power source of 12 Vdc. The limit switch output (Brown Wire) is connected to a 12V relay and the 4-20mA output (Blue Wire) is connected to current monitoring equipment. See figure 1 on page 7 for a wiring diagram.

The 4-20mA (Blue Wire) is proportional to the input pressure and operates independent of the low and high set points.

The operation of the limit switch output (Brown Wire) is described below.

When the pressure applied is within the control limits (between the low and high set points), the limit switch output will follow the external power source (12V).

When the pressure applied goes higher than the high limit set point or lower than the low limit set point, the limit switch output will shutoff (Output is 0 Volts).

The limit switch output will remain at 0 volts until the input pressure returns within controls limits (above the low limit set point and below the high pressure set point). When the pressure applied returns within limits, the limit switch output will once again follow the external power source (12V).

MediaGauge™ MG-MD Panel

MediaGauge™ MG-MD panel has a LCD display and three multi-functional buttons: ▶ ; **UNIT/SET**; ▲



To power on the unit: There is no ON/OFF button on the MediaGauge™ MG-MD model. The MG-MD unit is powered on and off via the external 12V supply voltage source.

When the external supply voltage is between 8 - 30 Vdc, the LCD will be backlit and will continuously display the pressure measurements.

SSI Technologies – Application Note PS-AN7

MediaGauge™ (Model MG-MD) Digital Pressure Gauge

Product Overview

To display the pressure reading in a different pressure unit: Press the **UNIT/SET button** until the arrow in the LCD points to the pressure units desired.

To check the value of the low pressure setting: Press and release the **▶ button**, the low pressure set point will be displayed for 30 seconds.

To check the value of the high pressure setting: Press and release the **▲ button**, the high pressure set point will be displayed for 30 seconds.

To see the maximum peak pressure the unit has measured: Press and hold down the **▶ button** for 3 seconds. The maximum peak pressure value will be displayed and will blink on the screen.

To reset the maximum peak pressure: Press and hold down the **▲ button** for 3 seconds, and the peak hold value will reset.

To return to the current pressure reading: Press and hold the **▶ button** for 3 seconds and the gauge will be back to the measurement mode, the current pressure measurement will be displayed and will not blink.

To reference your MediaGauge™ digital pressure gauge to the input port: Press and hold down the **▶ button** and the **▲ button** at the same time for 3 seconds. For example, if you have 20 psi on the display and then you press and hold down the **▶ button** and the **▲ button** simultaneously for 3 seconds, the display will show 0.0 psi. A measurement of 30 psi would then read as 10 psi on the display.

To reset the MediaGauge™ digital pressure gauge: Make sure the input port is either disconnected or connected to a 0 psi input. Press and hold down the **▶ button** and the **▲ button** at the same time for 3 seconds.

To set the High or Low pressure set points: Press and hold down the **UNIT/SET button** for 3 seconds. The MediaGauge™ MG-MD will go into the pressure setting mode.

- 1) The screen shows **▲** on the top, left hand side indicating high pressure setting, and the first digit will be flashing.
- 2) Set the first digit value by pressing the **▲ Button** (select from 0 to 9). Then press the **▶ Button**, which shifts to the second digit. Again use the **▲ Button** to select 0 thru 9 followed by the **▶ Button** to complete the third and fourth digits.
- 3) After all 4 digits of the high pressure settings are done press the **▶ Button** one more time, the screen will show **▼** on the top, left hand side indicating low pressure setting. Repeat steps 1 and 2 above to set the 4 digits of the low pressure settings.
- 4) After all 4 digits of the low pressure settings are done press the **▶ Button** one more time, the screen will show "Load", indicating your pressure settings have been saved into memory.
- 5) To make sure that the settings are correct, you can press the **▶ Button** to check the value of the low pressure setting and press the **▲ Button** to check the value of the high pressure setting.



SSI Technologies – Application Note PS-AN7

MediaGauge™ (Model MG-MD) Digital Pressure Gauge

Product Overview

Electrical Interface

MediaGauge™ MG-MD harness connections:

- White wire:** Power Lead for supply input (12 Vdc)
- Black wire:** Return Lead
- Brown wire:** Limit Switch output (NPN Transistor output)
- Blue Wire:** 4-20 mA output for meter. (Must be loop grounded with black wire)

Typical Wiring Interface

This is a description of an application to interface the MediaGauge™ MG-MD to a monitoring and control system utilizing the limit switch output to control a relay and monitor the output current. The relay will turn on and off based upon the high and low pressure set points the user programs into the MediaGauge™ MG-MD digital pressure gauge.

- 1) Mount the MediaGauge™ MG-MD digital pressure gauge on a suitable (1/4" NPT) female fitting. Use Teflon tape or pipe dope to seal the threads. . Do not over tighten. Torque to 150 in lbs +/- 1 in lb.
- 2) Connect the supplied mating harness with Din connector to the mating connector on the back of the MediaGauge™ MG-MD digital pressure gauge.
- 3) Program the MediaGauge™ digital pressure gauge with your low and high pressure set points per the instructions described previously.

- 4) Connect the brown wire to one side of the relay. Connect the other side of the relay to ground. Refer to Figure 1.

- 5) When monitoring the 4-20 mA current output with a **current meter**, Connect the current meter in series with the 4-20 mA output.

Connect the 4-20mA output (Blue Wire) to the + terminal of the current meter. Connect the – terminal of the current meter to ground.

- 6) When monitoring the 4-20 mA current output with a **voltage meter**, connect the 4-20mA output to an appropriate resistive load selected based on the value of your supply voltage. See Figure 2.

Connect the 4-20 mA output (Blue Wire) to one end of the resistive load. Connect the other end of the resistive load to ground.

Note: The 4-20mA (Blue Wire) must be connected directly to ground when not being used for monitoring purposes.



SSI Technologies – Application Note PS-AN7

MediaGauge™ (Model MG-MD) Digital Pressure Gauge

Product Overview

Electrical Specifications

Supply Voltage	8 - 30 Vdc supply
Response Time	< 1 ms
Accuracy (75-3000 PSI)	± 0.25 % FS
Thermal Error typ. (75-3000 PSI)	± 0.25 % FS
Total Error (75-3000 PSI)	± 0.25 % FS
Accuracy (15-50 PSI)	± 0.50 % FS
Thermal Error Typ. (15-50 PSI)	± 0.50 % FS
Total Error (15-50 PSI)	± 0.50 % FS
Stability (Typical)	< 0.25% Full Scale/Year
LCD Resolution (15 to 75 PSI)	XX.00
LCD Resolution (100 to 750 PSI)	XXX.0
Proof Pressure	3 X Full Scale
Burst Pressure	10X Full Scale
Zero Pressure Offset	4 mA
Full Scale Output	20 mA
Operating Temperature Range	-10° to 60°C (14° to 140°F)
Storage Temperature Range	-20° to 85°C (-4° to 185°F)

Tested Conditions

Humidity	250 Hours (40°C and 90% to 95% R.H.)
Pressure/Temperature Cycles	> 1.8 million Cycles (0 to FS @ 8Hz and -20° to 85°C)
Thermal Shock	250 Cycles (85 to -20°C. 0.5 hr soaks at temperature)
Vibration	144 Hours (100 to 2000 Hz, 20g sinusoidal in 3 axes)

SSI Technologies – Application Note PS-AN7

MediaGauge™ (Model MG-MD) Digital Pressure Gauge

Product Overview

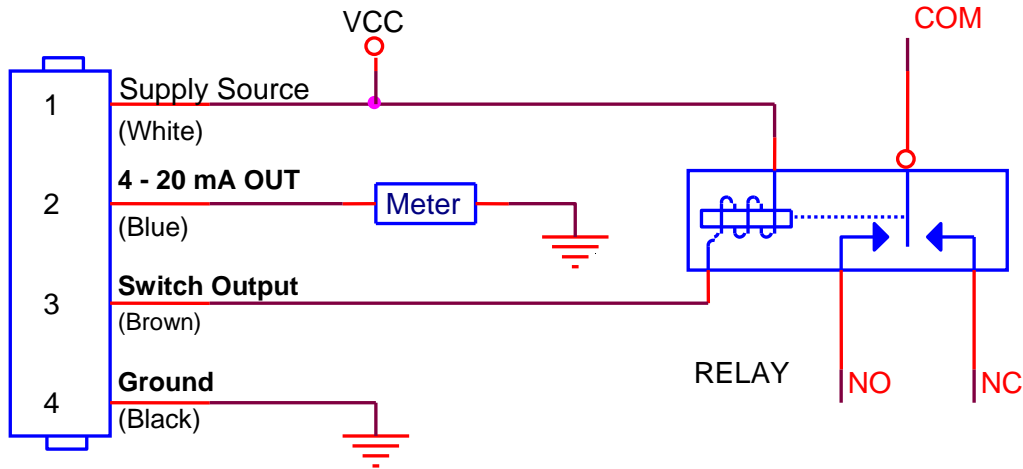

MediaGauge™
4 Pin Mini DIN

Figure 1. Typical MediaGauge™ MG-MD Digital Pressure Gauge Application Wiring Diagram

SSI Technologies – Application Note PS-AN7

MediaGauge™ (Model MG-MD) Digital Pressure Gauge

Product Overview

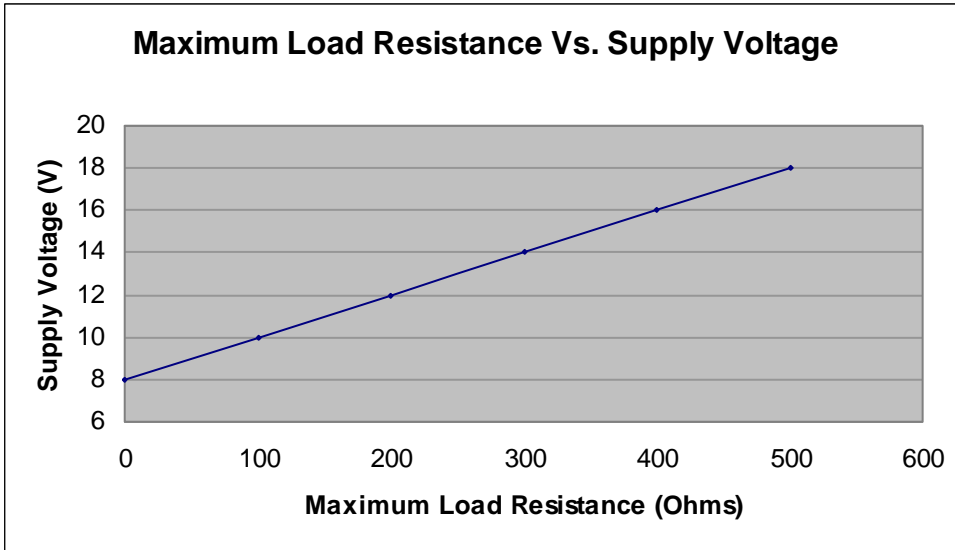

Figure 2. Load Resistance Values for 4-20mA output

SSI Technologies – Application Note PS-AN7

MediaGauge™ (Model MG-MD) Digital Pressure Gauge

Product Overview

Mating Connector and 2 meters of cable included with MD version

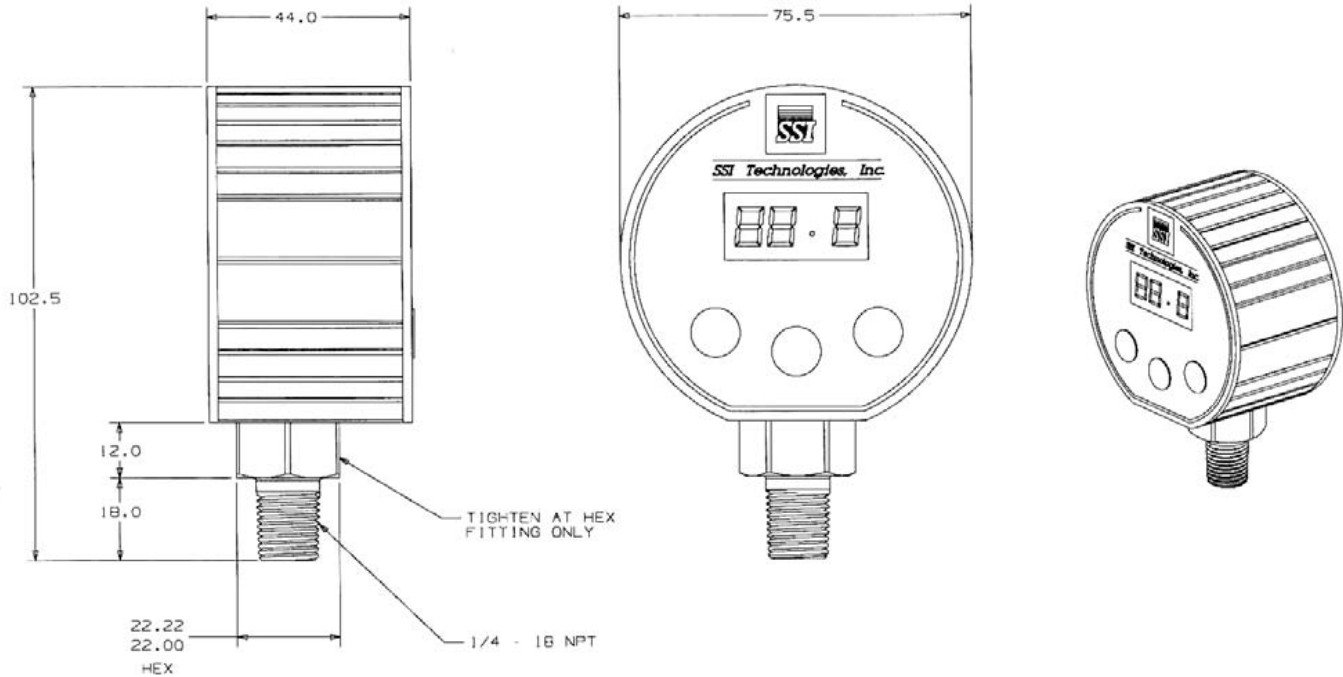

MediaGauge™ with 22mm Hex and 1/4" - 18 NPT Process Connection

SSI TECHNOLOGIES, INC.
 Controls Division
 2643 West Court Street
 Janesville, WI 53548-5011
 Phone: (608)758-1500
 Fax: (608)758-2491



Copyright September 24, 2008
 SSI Technologies Inc.
 All Rights Reserved
 Revision 3



SSI Technologies – Application Note PS-AN7

MediaGauge™ (Model MG-MD) Digital Pressure Gauge

Product Overview

Digital Pressure Gauge Ordering System

The following explains SSI's MediaGauge™ Digital Pressure Gauge order number sequence.

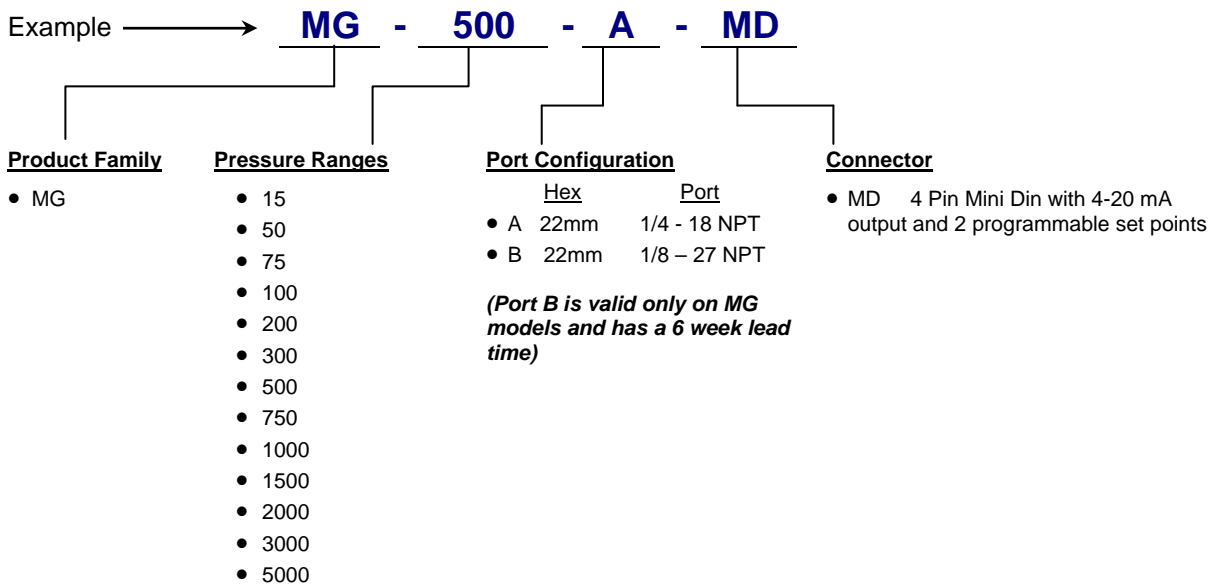

Rubber Boot:

Order P/N 14405.1 for Model MG